

G5 CABLE MOTION™ GYM SYSTEM

ASSEMBLY INSTRUCTIONS

G5-001 / CLASS H / 09/30/08 / 8289201 REV. B

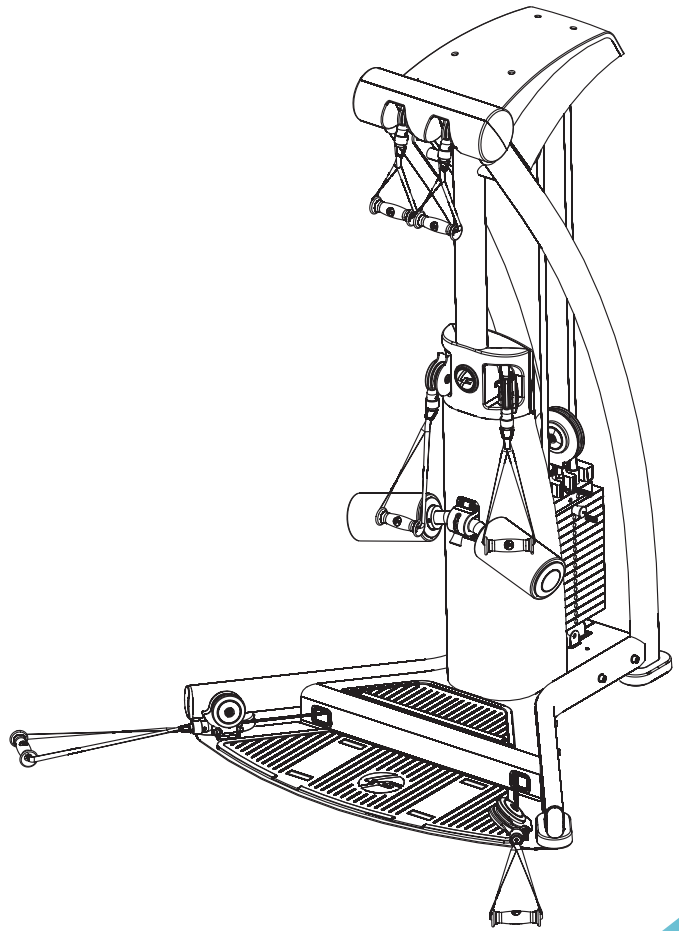

TABLE OF CONTENTS

Safety Statement	2	Hardware	8
G5 Warning Labels	4	Assembly Instructions	10
Gym Dimensions.	5	General Maintenance	22
G5 Live Area	6	Warranty Statement/Notes	23
Components List	7	Contact Information.	24

SAFETY INFORMATION

It is the sole responsibility of the purchaser of LIFE FITNESS products to read the owner's manual, warning labels and instruct all individuals, whether they are the end user or supervising personnel on proper usage of the equipment.

UNDERSTANDING EACH AND EVERY WARNING TO THE FULLEST IS IMPORTANT. IF ANY OF THESE INSTRUCTIONS OR WARNINGS ARE UNCLEAR, CONTACT LIFE FITNESS CUSTOMER SERVICE IMMEDIATELY AT 1-800-351-3737 WITHIN THE US AND CANADA. INTERNATIONAL OFFICE CONTACT INFORMATION IS AVAILABLE ON PAGE 24.

Keep children away from strength equipment. Parent or others supervising children must provide close supervision of children if the equipment is used in the presence of children.

This equipment is categorized as class H per EN 957-1. And as such this equipment is only intended for Home use. It is not intended for commercial, institutional and/or studio facilities use. Contact LIFE FITNESS with any questions regarding this classification.

It is recommended that all users of LIFE FITNESS exercise equipment be informed of the following information prior to use.



ACCESS CONTROL

LIFE FITNESS recommends that all fitness equipment be used in a supervised area. It is recommended that the equipment be located in an access controlled area. Control is the responsibility of the facility owner.



INSTALLATION

SECURING EQUIPMENT - LIFE FITNESS recommends that all equipment be secured to a solid, level surface to stabilize and eliminate rocking or tipping over. This must be performed by a licensed contractor.



PROPER USAGE

1. Do not use any equipment in any way other than as designed or intended by the manufacturer. It is imperative that LIFE FITNESS equipment is used properly to avoid injury.
2. Injuries may result if exercising improperly or excessively. It is recommended that all individuals consult a physician prior to commencing an exercise program. If at any time during exercise you feel faint, dizzy or experience pain, STOP EXERCIZING and consult your physician.
3. Keep body parts (hands, feet, hair, etc.), clothing and jewelry away from moving parts to avoid injury.
4. When adjusting any seat, knee hold down pad, range of motion limiter, foothold pad, pulley or any other type of adjuster, make certain that the adjusting pin is fully engaged in the hole to avoid injury.



INSPECTION

1. DO NOT use or permit use of any equipment that is damaged and or has worn or broken parts. For all LIFE FITNESS equipment use only replacement parts supplied by LIFE FITNESS.
2. Cables and Belts pose an extreme liability if used when frayed. Always replace any cable at first sign of wear (consult LIFE FITNESS if uncertain).
3. Routinely inspect all accessory clips that join attachments to the cables and replace at the first sign of wear.
4. MAINTAIN LABELS AND NAMEPLATES - Do not remove labels for any reason. They contain important information. If unreadable or missing, contact LIFE FITNESS for a replacement.
5. EQUIPMENT MAINTENANCE - Preventative maintenance is the key to smooth operating equipment as well as keeping your liability to a minimum. Equipment needs to be inspected at regular intervals.
6. Ensure that any person(s) making adjustments or performing maintenance or repair of any kind is qualified to do so. LIFE FITNESS will provide service and maintenance training at our corporate facility upon request or in the field if proper arrangements are made.
7. Before any use, examine all accessories approved for use with the LIFE FITNESS equipment for damage or wear.
8. DO NOT ATTEMPT TO USE OR REPAIR ANY ACCESSORY APPROVED FOR USE WITH THE LIFE FITNESS EQUIPMENT WHICH APPEARS TO BE DAMAGED OR WORN.



OPERATING WARNINGS

1. It is the purchaser's sole responsibility to properly instruct its end users and supervising personnel as to the proper operating procedures of all LIFE FITNESS equipment.
2. Keep children away from strength equipment. Parent or others supervising children must provide close supervision of children if the equipment is used in the presence of children.
3. Do not allow users to wear loose fitting clothing or jewelry while using equipment. It is also recommended to have user's secure long hair back and up to avoid contact with moving parts.
4. All bystanders must stay clear of all users, moving parts and attached accessories and components while machine is in operation.



SELECTORIZED WEIGHT STACK SYSTEMS

1. Use only weight selector pins supplied by LIFE FITNESS on weight stacks. Substitutes are forbidden.
2. Fully insert weight selector pins. Partial insertion can cause weights to fall unexpectedly.
3. Never pin the weight stack in an elevated position.
4. Never remove selector pin if any weights are suspended.
5. Never attempt to release jammed weights or parts.
6. Never use dumbbells or other means to incrementally increase the weight resistance. Use only those means provided by LIFE FITNESS.

G5 WARNING LABELS

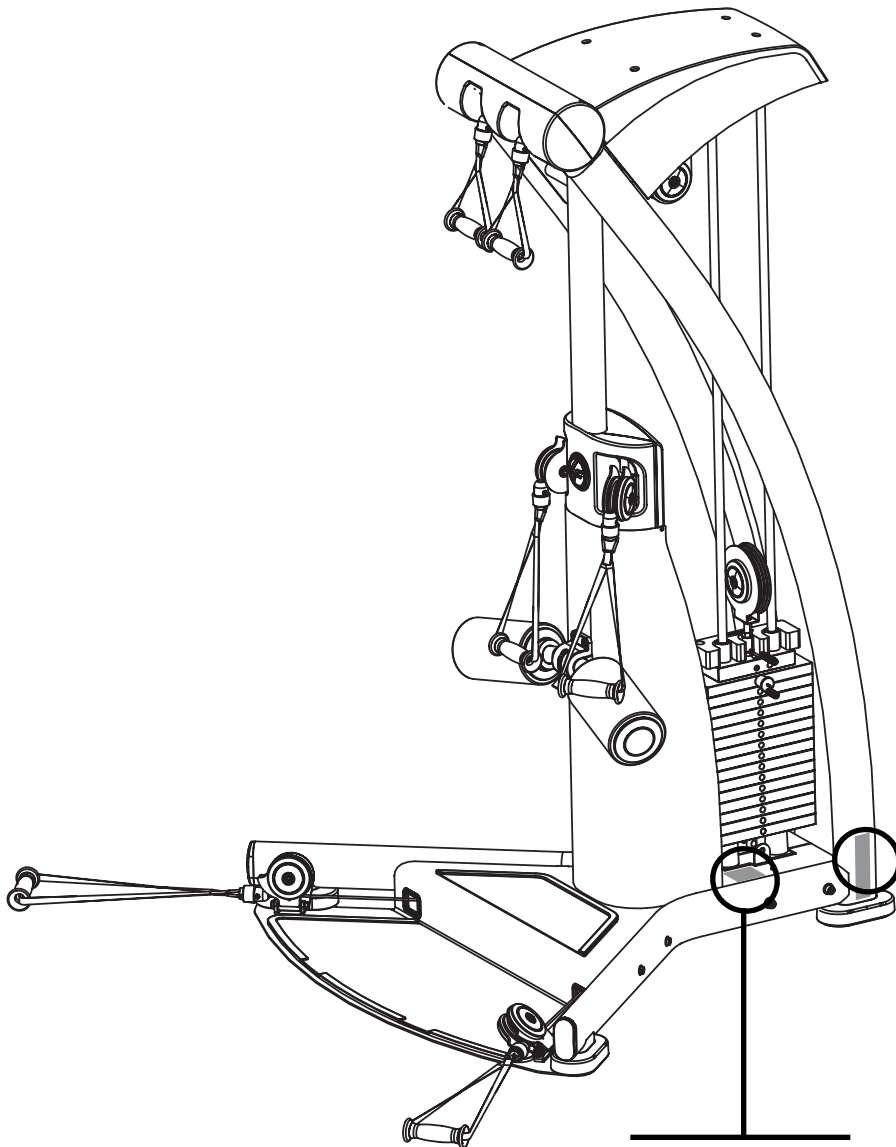

⚠ WARNING

SERIOUS INJURY CAN OCCUR ON THIS EQUIPMENT. YOU MUST FOLLOW THESE PRECAUTIONS TO AVOID INJURY!

1. Before using, read all the warnings and obtain instruction on the use of this machine. Use only for intended exercise. **DO NOT** modify the machine.
2. Obtain a medical exam before beginning any exercise program.
3. Keep body, hair and clothing free of all moving objects.
4. Inspect the machines before use. **DO NOT** use if it appears damaged. **DO NOT** attempt to fix a broken or jammed machine. Notify staff immediately.
5. Be certain that weight pin is completely inserted. Use only the pin provided by the manufacturer. If unsure, seek assistance.
6. Never pin the weights or prop plate into an elevated position. **DO NOT** use the machine if found in this condition. **DO NOT** attempt to fix. Seek assistance.
7. Inspect cables and their connections before using machine. **DO NOT** attempt to fix. Seek assistance.
8. Use only the incremental weights supplied by the manufacturer. **DO NOT** use dumbbells or other means to add resistance to the machine.
9. Children must not be allowed near this machine. Supervise teenagers.
10. Manufacturer recommends that all equipment be secured to the floor to stabilize and eliminate rocking or tipping over. Use a licensed contractor.
11. **DO NOT REMOVE THIS LABEL. REPLACE IF DAMAGED.**

⚠ WARNING

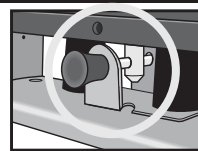

Lock weight stack when machine is not in use.

NOTE: Lock the weight stack when not using the gym. Make sure all the weight plates are resting on the plate below with no gap in between. Insert the weight selector pin in the tab underneath the weight stack. The weight selector pin should be inserted until the knob touches the metal tab. Once the pin goes through the weight stack system, the weight stack becomes immobile. Verify that the pin has gone through the weight stack stem.

GYM DIMENSIONS

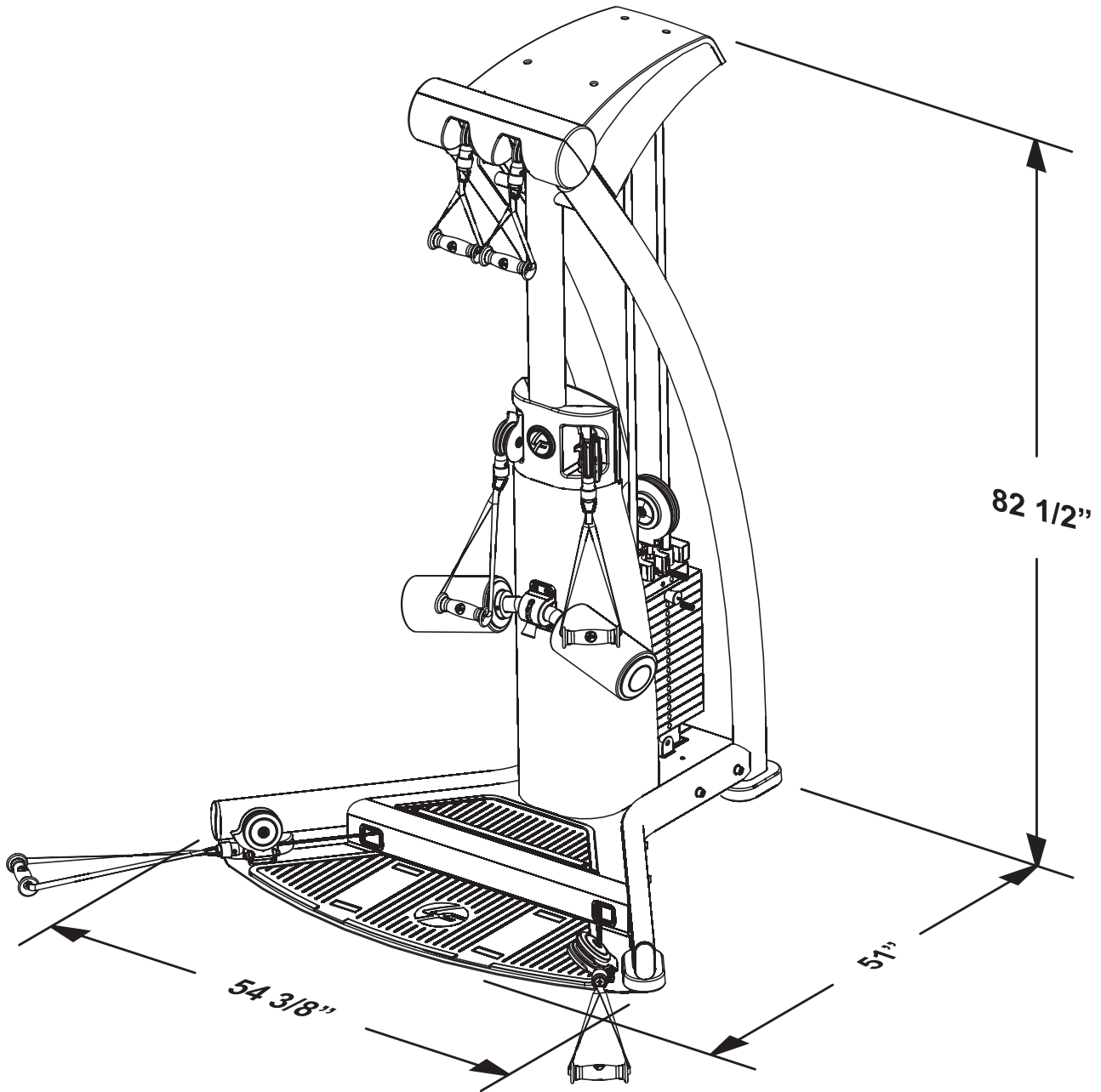

Resistance Ratio: 1:2
Machine Weight: 500 pounds
Weight Stack: 160 pounds

G5 LIVE AREA

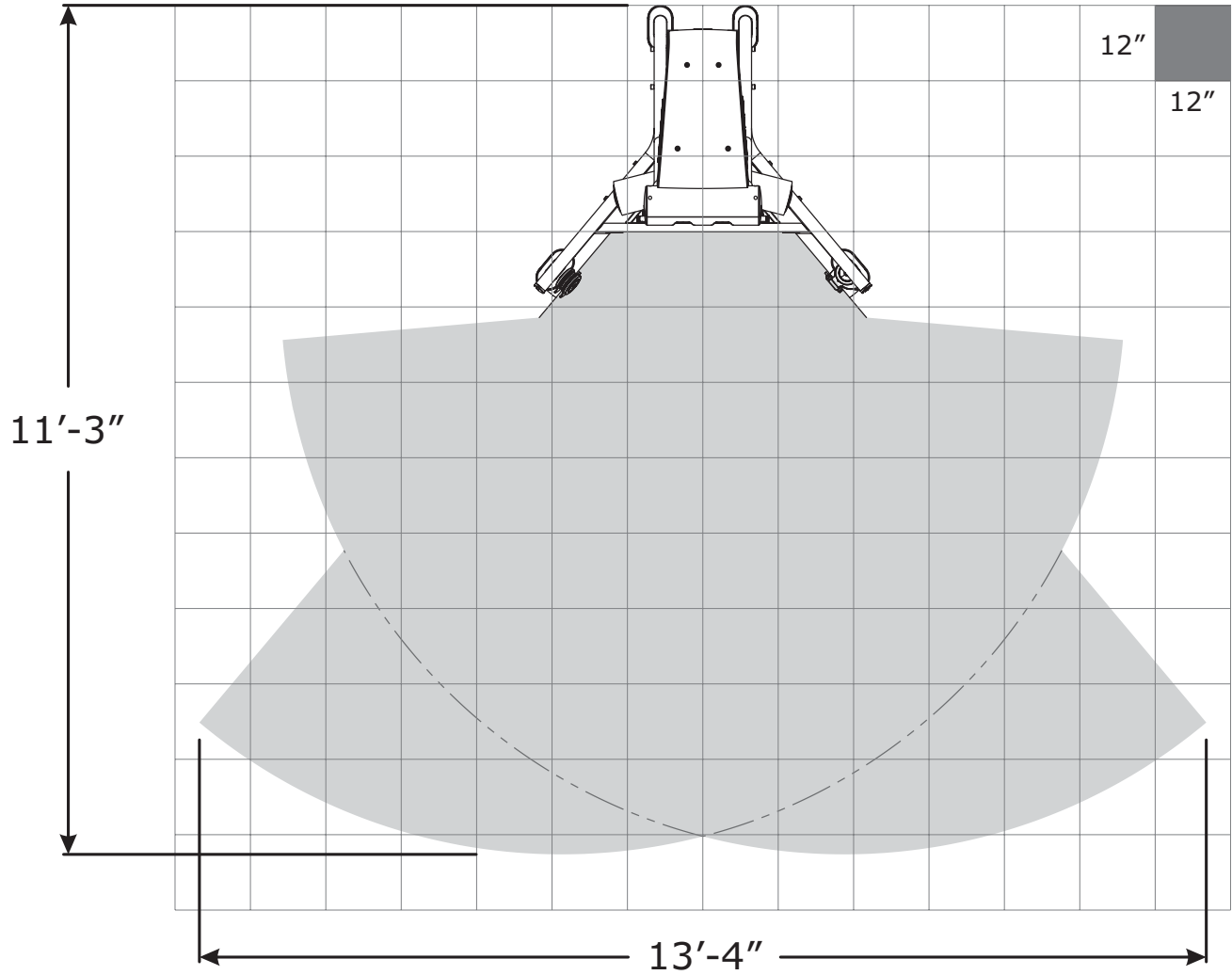

NOTE: The live area shows the extent of the G5 gym. It does not include the user.

COMPONENTS LIST

NOTE: This component list is for ASSEMBLY ONLY. For ordering serviceable parts, please go to:
<http://us.home.lifefitness.com/content.cfm/servicedocuments>

ITEM NO.	QTY.	DESCRIPTION
1	1	FRONT UPRIGHT
2	1	UPPER SWIVEL PULLEYS
3	1	LEFT UPRIGHT
4	1	RIGHT UPRIGHT
5	1	LEFT BASE
6	1	RIGHT BASE
7	1	FOOT PLATE
8	2	GUIDE ROD
9	15	WEIGHT PLATE
10	1	HEAD PLATE PULLEY
11	1	SELECTOR PIN
12	1	TOP PLATE
13	2	WEIGHT STACK CUSHION
14	2	FLOATING PULLEYS
15	1	FRONT SHROUD
16	1	RIGHT BOTTOM PLATE
17	1	LEFT BOTTOM PLATE
18	1	BACK THIGH HOLD CLAMP
19	1	THIGH HOLD DOWN
20	1	TOP BACK COVER
21	1	TOP FRONT COVER
22	1	MOUNTING SHEET
23	1	TOP COVER
24	1	TOP RIGHT COVER
25	1	TOP LEFT COVER
26	2	SHORT HANDLE
27	2	MEDIUM HANDLE
28	2	ADJUSTABLE HANDLE
29	1	UPPER (LONG) CABLE
30	2	LOWER (SHORT) CABLE
31	2	GUIDE CABLE
32	6	QUICK CONNECT
33	1	FOOT STRAP
34	1	THIGH STRAP
35	1	ADAPTER BAR
36	2	SNAP LINKS
37	2	UNIVERSAL RINGS
38	1	EXERCISE BALL

COMPONENTS LIST

HARDWARE		
ITEM NO.	QTY.	DESCRIPTION
39	14	3/8" WASHER
40	4	M10 X 30MM SCREW
41	8	M10 X 70MM SCREW
42	4	M12 X 80MM SCREW
43	8	1/2" WASHER
44	4	M12 HEX NYLOCK NUT
45	2	M10 X 50 HEX TENSION SCREW
46	2	GUIDE ROD RETAINER
47	4	M4 X 0.7MM ZINC PHILLIPS PAN HEAD SCREW
48	2	M10 X 20MM SCREW
49	2	RETAINING RING
50	4	#10-32 X 3/4" PHILLIPS PAN HEAD SCREW
51	2	M6 X 60MM SCREW
52	2	1/4" WASHER
53	4	M10 HEX NYLOCK NUT
54	8	M4 ZINC PHILLIPS PAN HEAD SCREW
55	2	#6 X 3/8" BLACK PHILLIPS PAN HEAD SCREW
REQUIRED TOOLS		
ADJUSTABLE WRENCH		
EXTERNAL SNAP RING PLIERS		
PHILLIPS SCREW DRIVER		
ALLEN WRENCHES (4mm, 7mm, 8mm)		
WRENCHES (13mm, 17mm, 19mm)		

HARDWARE:

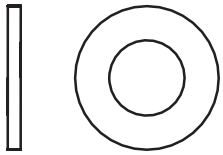

3/8" WASHER (#39)

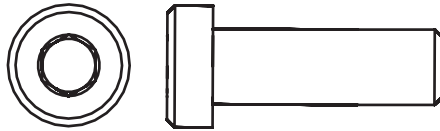

M10 X 30MM SCREW (#40)

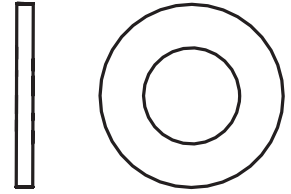

1/2" WASHER (#43)

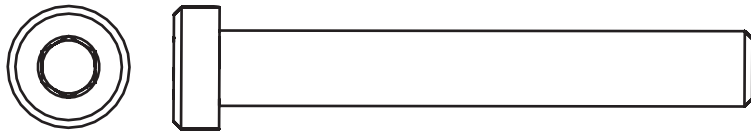

M10 X 70MM SCREW (#41)

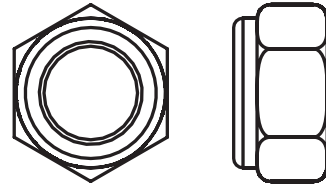

M12 HEX NYLOCK NUT (#44)

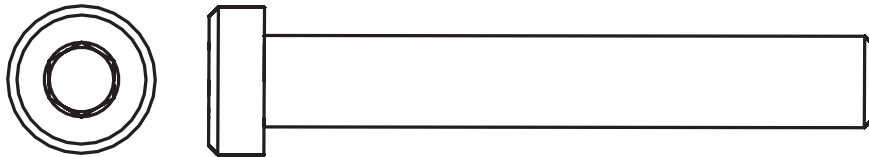

M12 X 80MM SCREW (#42)

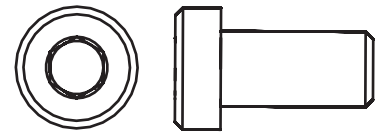

M10 X 20MM SCREW (#48)



M10 X 50MM HEX TENSION SCREW (#45)



M4 X 0.7mm ZINC PHILLIPS PAN HEAD SCREW (#47)

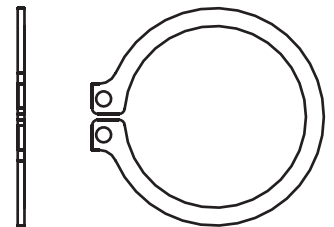

RETAINING RING (#49)



#10-32 X 3/4" PHILLIPS PAN HEAD SCREW (#50)

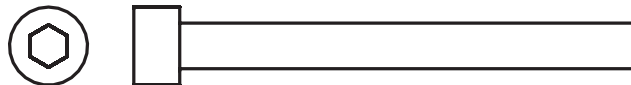

M6 X 60MM SCREW (#51)



1/4" WASHER (#52)

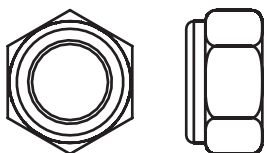

M10 HEX NYLOCK NUT (#53)



M4 ZINC PHILLIPS PAN HEAD SCREW (#54)



#6 X 3/8" BLACK PHILLIPS PAN HEAD SCREW (#55)

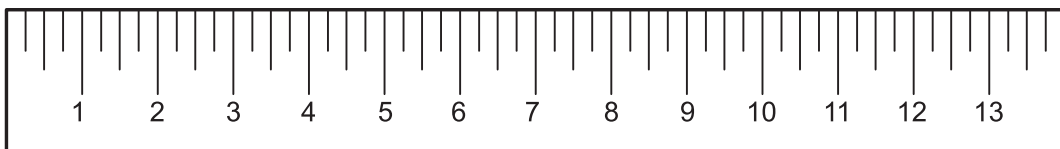

Centimeters

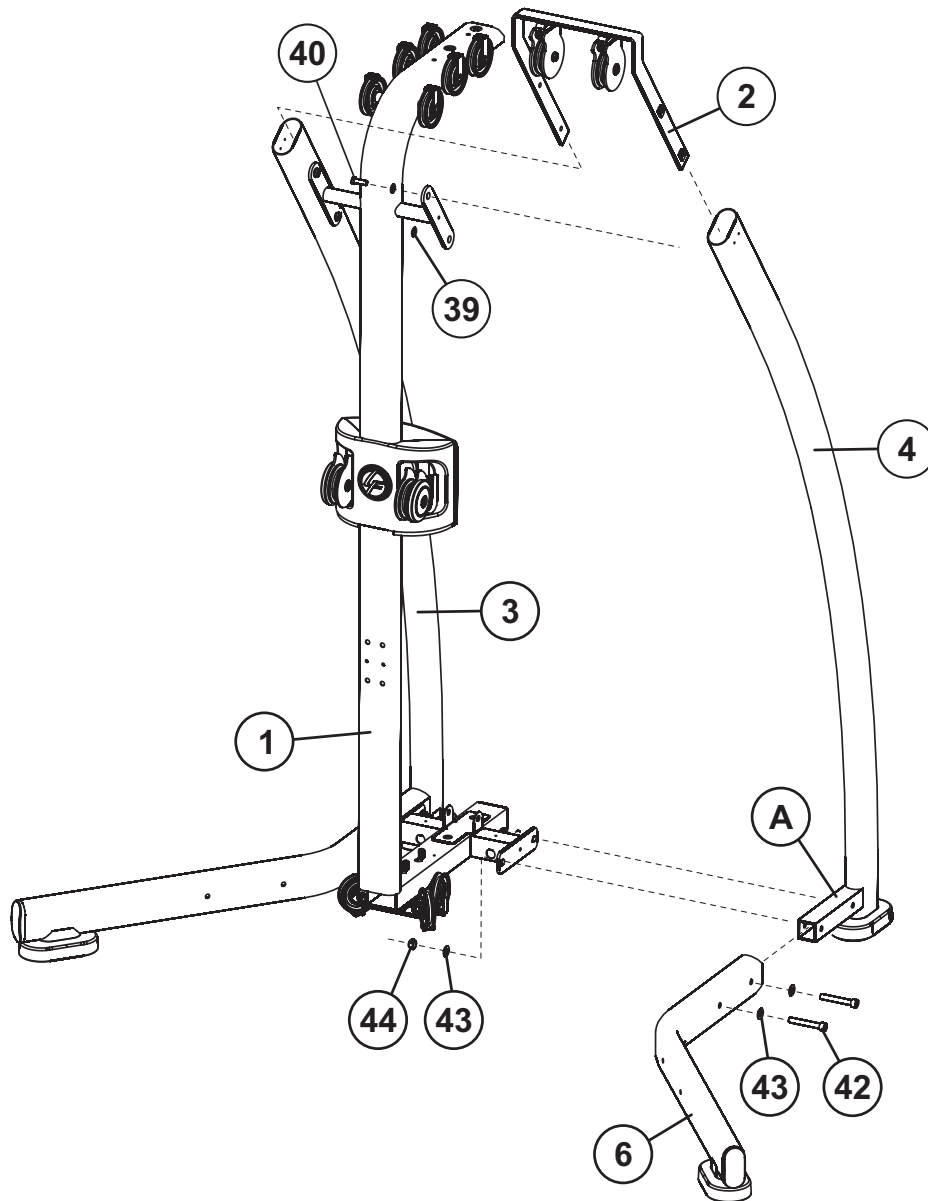

STEP 1:

- ❑ Slide the RIGHT BASE (6) over the MOUNTING TUBE (A) of the RIGHT UPRIGHT (4). Loosely secure the RIGHT BASE (6) and RIGHT UPRIGHT (4) to the FRONT UPRIGHT (1) using two M12 x 80mm SCREWS (42), four 1/2" WASHERS (43), and two M12 HEX NYLOCK NUTS (44) as shown.
- ❑ With the UPPER SWIVEL PULLEYS (2) oriented as shown, insert the UPPER SWIVEL PULLEYS (2) into the top of the RIGHT UPRIGHT (4) and secure together the RIGHT UPRIGHT (4), FRONT UPRIGHT (1), and UPPER SWIVEL PULLEYS (2) using two M10 x 30mm SCREWS (40) and two FLAT 3/8" WASHERS (39).
- ❑ Repeat the above steps to assemble the LEFT UPRIGHT (3) and LEFT BASE (5) to the FRONT UPRIGHT (1).

NOTE: THE UPPER SWIVEL PULLEYS (2) ATTACH TO THE INSIDE OF THE UPRIGHT SIDES AND THE ORIENTATION SHOULD BE AS SHOWN.

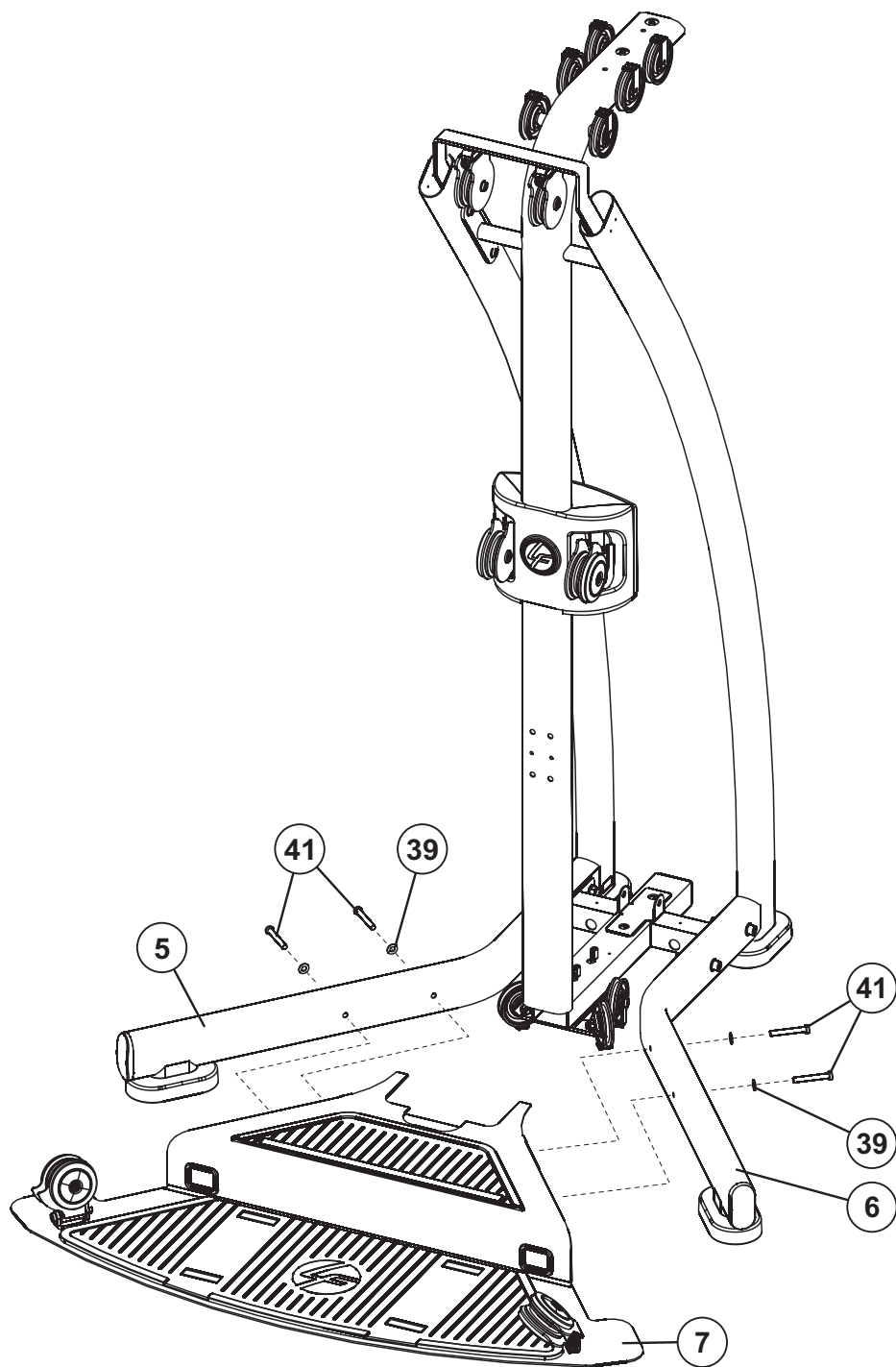

STEP 2:

- ❑ **LOOSELY** attach the FOOTPLATE (7) to the RIGHT BASE (6) and LEFT BASE (5) using four M10 x 70mm SCREWS (41) and four FLAT 3/8" WASHERS (39).

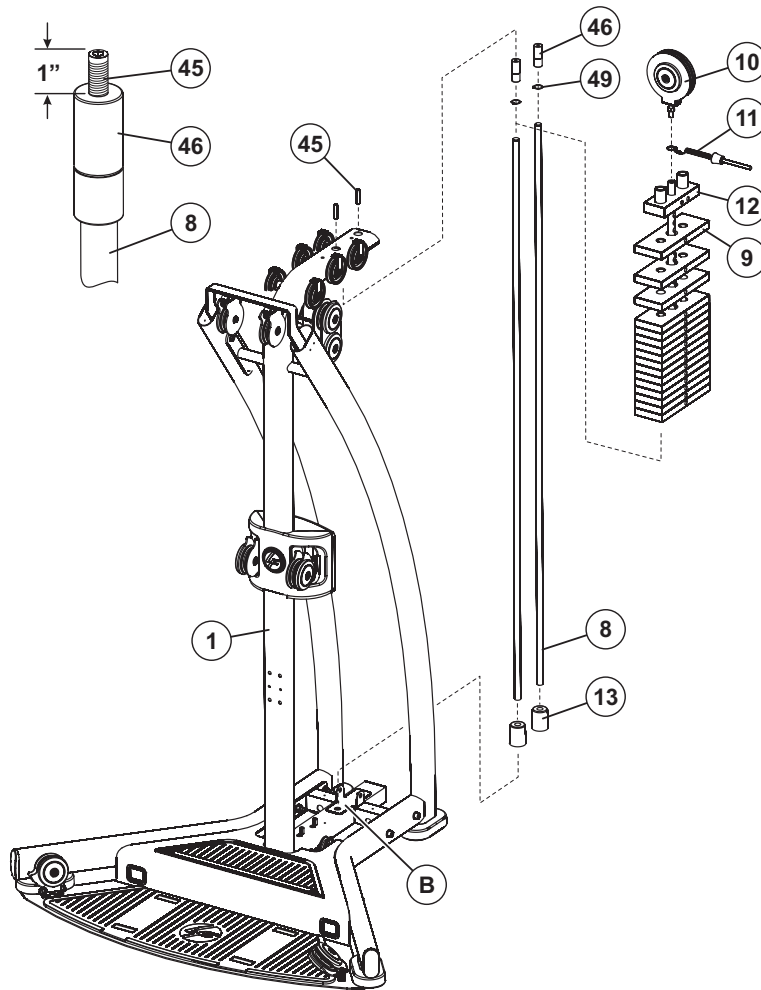

STEP 3:

- Position two WEIGHT STACK CUSHIONS (13) and GUIDE RODS (8) at the GUIDE ROD BRACKET (B) on the bottom of the FRONT UPRIGHT (1).

NOTE: MAKE SURE THAT THE PLUGGED ENDS OF THE GUIDE RODS (8) ARE FACING UP.

- CAREFULLY** slide one of the WEIGHT PLATES (9) over the top of the GUIDE RODS (8) and slowly lower the WEIGHT PLATE (9) on to the WEIGHT STACK CUSHIONS (13).
- Continue stacking a total of 15 WEIGHT PLATES (9).
- Slide the TOP PLATE (12) over the GUIDE RODS (8) and slowly lower it onto the WEIGHT PLATES (9).
- Slide the SELECTOR PIN (11) over the stem of the TOP PLATE (12).
- Thread the HEAD PLATE PULLEY (10) into the TOP PLATE (12).
- Slide one RETAINING RING (49) over the top of each of the GUIDE RODS (8).
- Thread one M10 x 50mm HEX TENSION SCREW (45) into each of the two GUIDE ROD RETAINERS (46). Do not fully thread the M10 x 50mm HEX TENSION SCREWS (45) into the GUIDE ROD RETAINERS (46).
- CAREFULLY** slide the GUIDE ROD RETAINERS (46) into the hole under the top of the FRONT UPRIGHT (1). Make sure the M10 x 50mm HEX TENSION SCREWS (45) in the GUIDE ROD RETAINERS (46) are facing up.
- Push the GUIDE ROD RETAINERS (46) up high enough so that the GUIDE RODS (8) can be placed under them.
- Lower the GUIDE ROD RETAINERS (46) over the GUIDE RODS (22).
- Slide the RETAINING RINGS (49) up. Use External Snap Ring Pliers to secure the RETAINING RINGS (49) into the groove on the GUIDE ROD RETAINERS (46).
- Tighten all frame bolts securely.

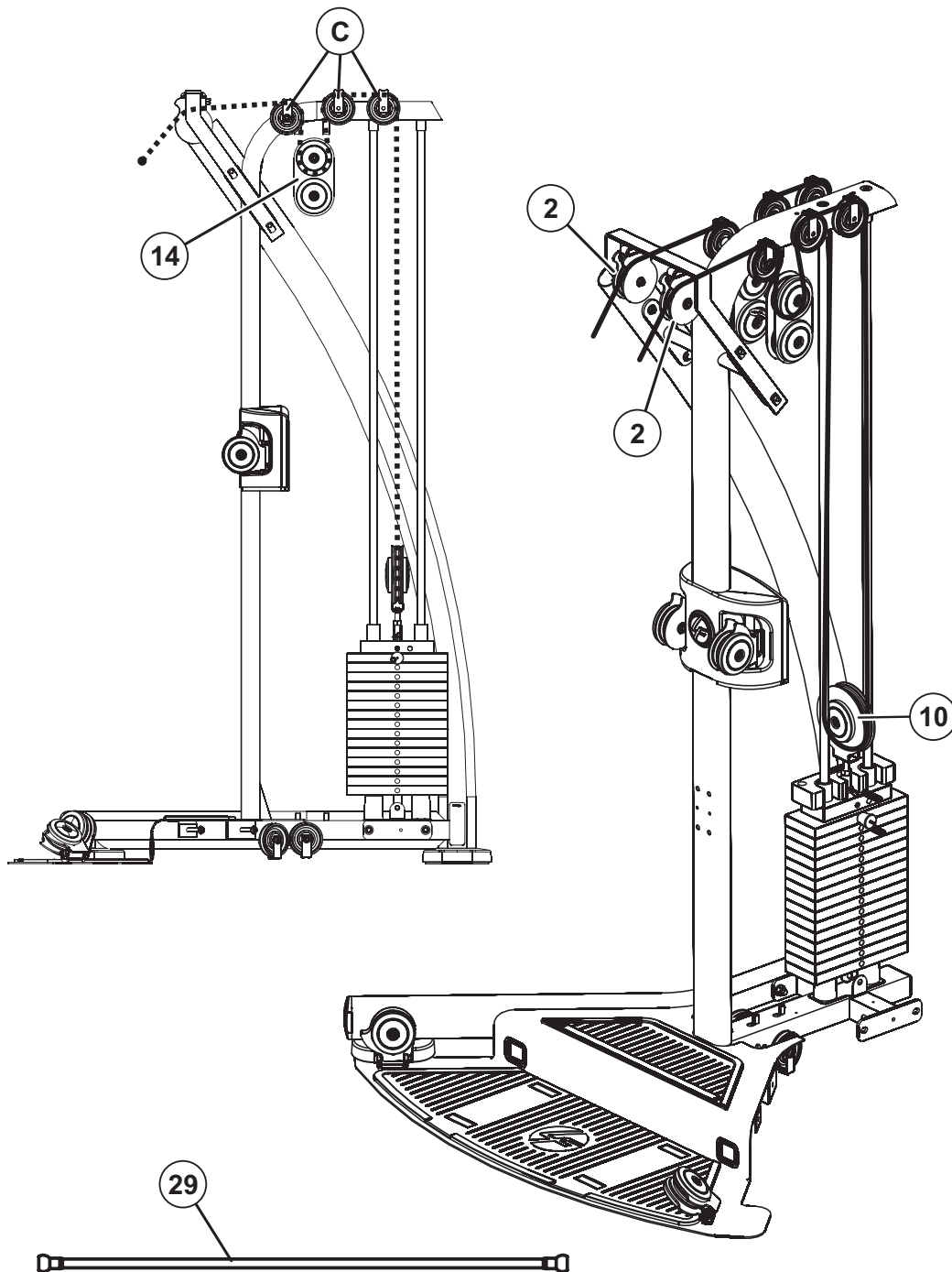

STEP 4:

- ❑ Remove one QUICK CONNECT from the end of one UPPER (LONG) CABLE (29).
- ❑ Insert the end (where the QUICK CONNECT was removed) of the UPPER (LONG) CABLE (29) through the UPPER SWIVEL PULLEYS (2) and follow routing illustration to the FLOATING PULLEYS (14) through to the HEAD PLATE PULLEY (10). Continue to the other side, ending at the other UPPER SWIVEL PULLEYS (2). Reattach the previously removed QUICK CONNECT to the end of the UPPER (LONG) CABLE (29).

NOTE: THE CABLE MUST BE INSERTED BETWEEN THE PULLEY AND THE CABLE RETAINING CLIPS (C) AND MOVE FREELY.

ITEM	QTY.	DESCRIPTION
32	6	QUICK CONNECT ASSEMBLY
D	1	QUICK CONNECT COUPLER
E	1	QUICK CONNECT HOUSING
F	1	QUICK CONNECT SLEEVE
G	1	COMPRESSION SPRING
H	2	M5 HEX SCREWS

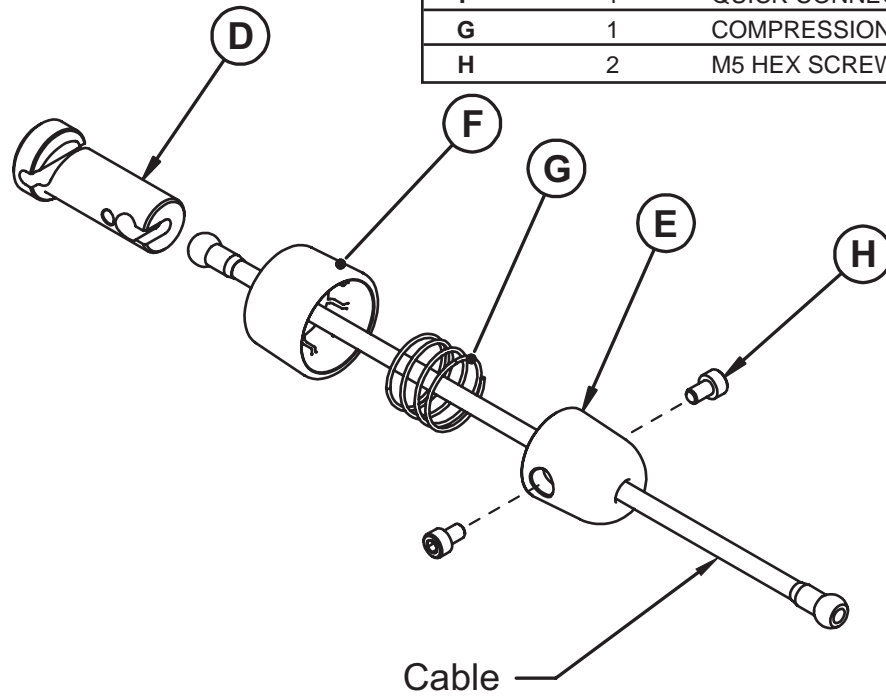

Slide Mechanism to insert or Exchange Handles

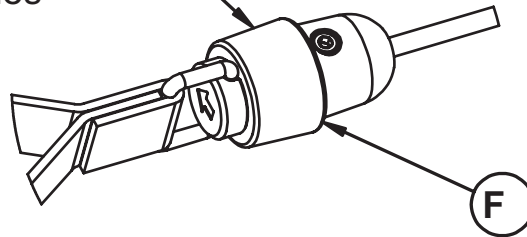

STEP 5:

- ❑ Disassemble the QUICK CONNECT (32) by removing the two M5 HEX SCREWS (H) from the QUICK CONNECT COUPLER (D). Carefully remove the COMPRESSION SPRING (G), the QUICK CONNECT SLEEVE (F) and the QUICK CONNECT HOUSING (E).
- ❑ Slide the QUICK CONNECT HOUSING (E), COMPRESSION SPRING (G), and QUICK CONNECT SLEEVE (F) onto the cable as shown. Insert the cable end into the QUICK CONNECT COUPLER (D).
- ❑ Slide the entire assembly over the QUICK CONNECT COUPLER (D). Attach the QUICK CONNECT COUPLER (D) and QUICK CONNECT HOUSING (E) together. Use the two M5 HEX SCREWS (H) to tighten.

NOTE: IF NECESSARY, ENSURE THE CABLES ARE THE PROPER LENGTH AND MAKE NECESSARY ADJUSTMENTS TO THE WEIGHT STACK PULLEY (TIGHTEN OR LOOSEN).

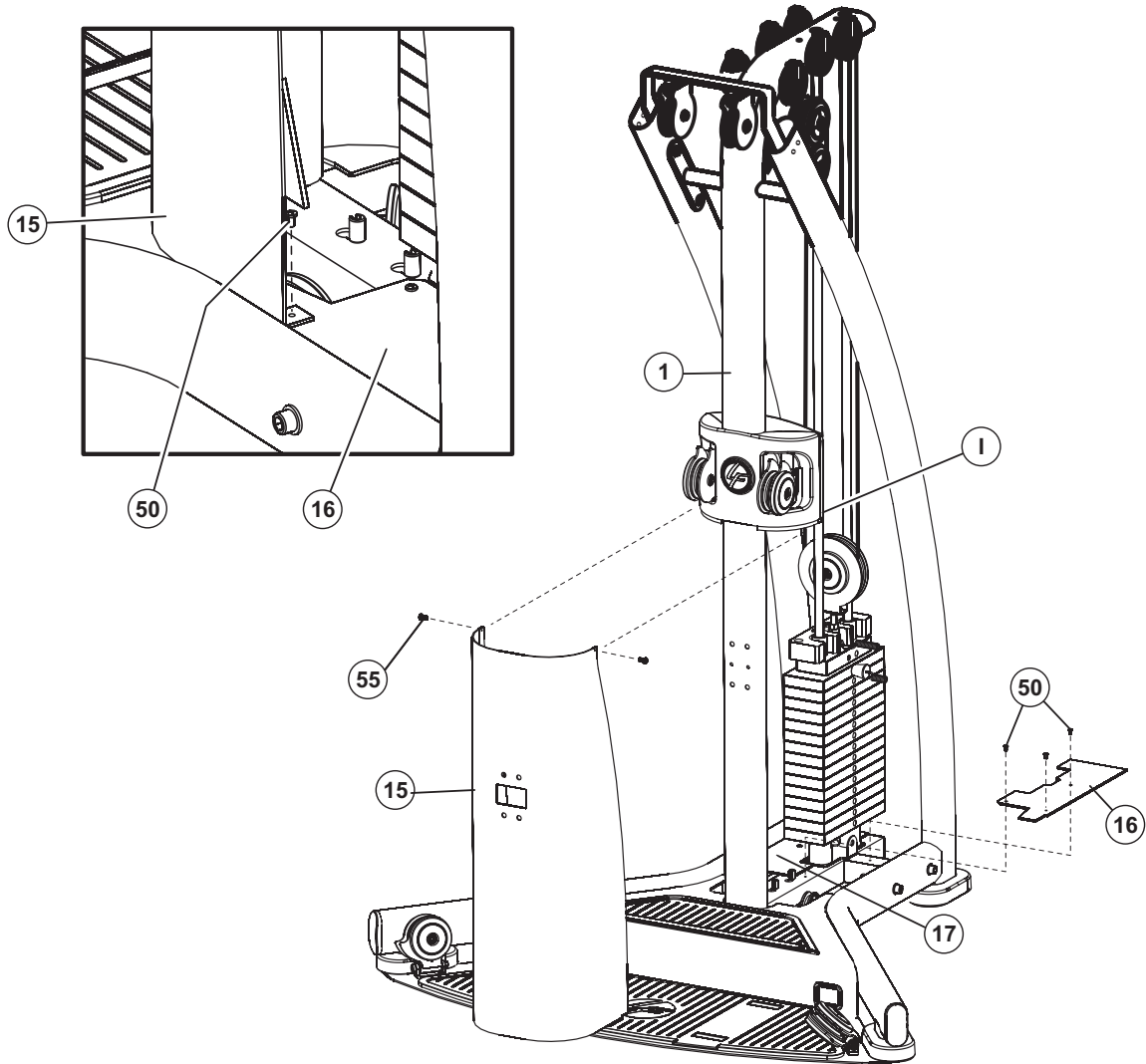

STEP 6:

- ❑ Mount the RIGHT BOTTOM PLATE (16) and the LEFT BOTTOM PLATE (17) to the FRONT UPRIGHT (1) using two 10-32 x 3/4" PHILLIPS PAN HEAD SCREWS (50) for each plate.
- ❑ Place the FRONT SHROUD (15) around the FRONT UPRIGHT (1).
- ❑ Align the bottom mounting holes of the FRONT SHROUD (15) with the remaining mounting holes on the RIGHT BOTTOM PLATE (16) and the LEFT BOTTOM PLATE (17). Secure with one 10-32 x 3/4" PHILLIPS PAN HEAD SCREW (50) on each plate.
- ❑ Attach the bottom corners of the MID BACK COVER (I) to the back of the FRONT SHROUD (15) using two #6 x 3/8" (9.5mm) BLACK PHILLIPS PAN HEAD SCREWS (55). DO NOT OVERTIGHTEN SCREWS INTO PLASTIC PARTS.

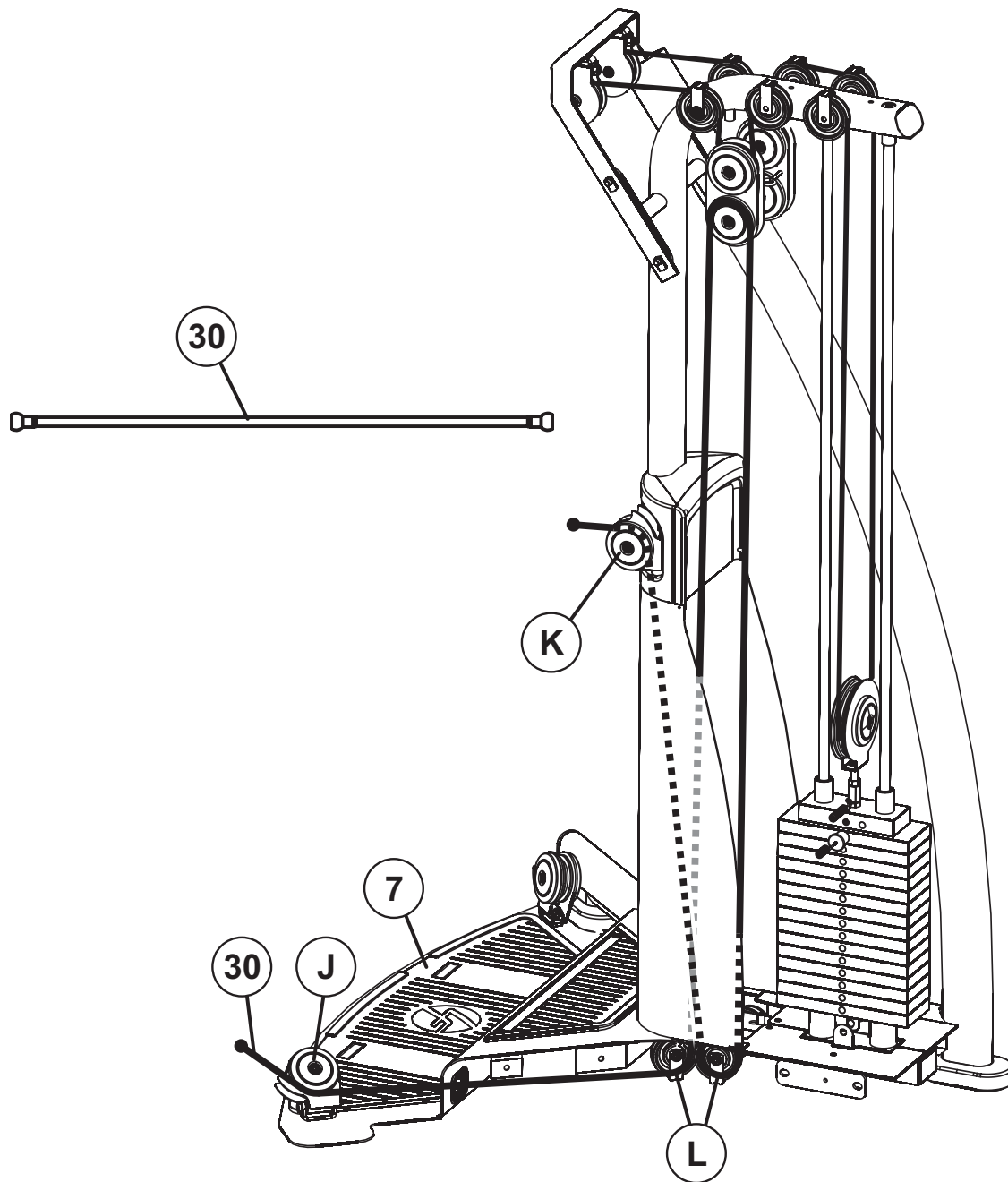

STEP 7:

- ❑ Remove one QUICK CONNECT from the end of one LOWER (SHORT) CABLE (30).
- ❑ Insert the end (where the QUICK CONNECT was removed) of the the LOWER (SHORT) CABLE (30) through the LOWER RIGHT PULLEY (J) and through the access hole in the FOOTPLATE (7). Continue routing the cable as shown ending at the RIGHT MID PULLEY ASSEMBLY (K). Reattach the previously removed QUICK CONNECT to the end of the LOWER (SHORT) CABLE (30).

NOTE: THE CABLE MUST BE INSERTED BETWEEN THE PULLEY AND THE PULLEY GUIDE (L) AND MOVE FREELY.

- ❑ Repeat the routing on the left side of the unit using the remaining LOWER (SHORT) CABLE (30).

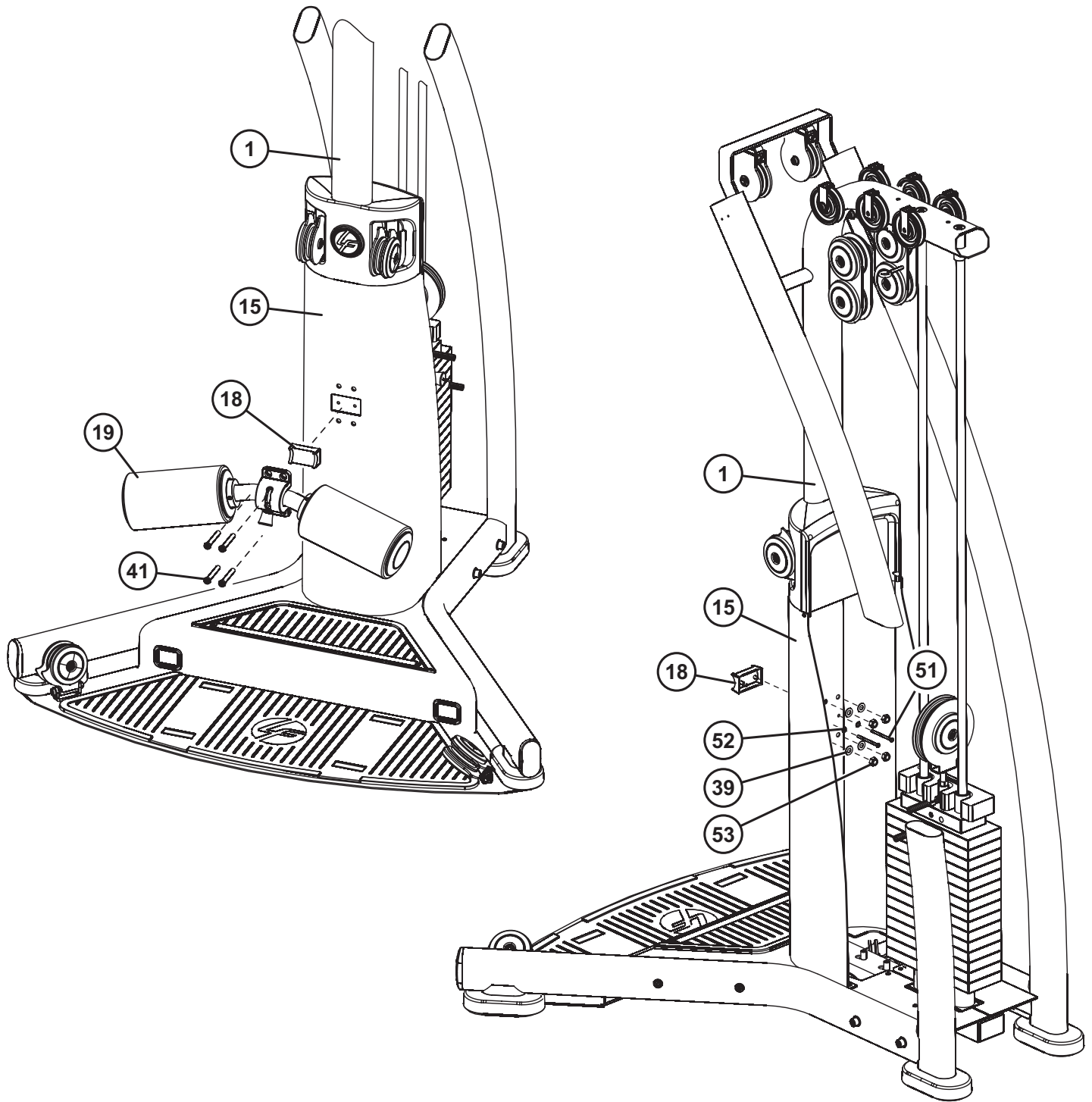

STEP 8:

- ❑ Attach the BACK THIGH HOLD CLAMP (18) to the the FRONT UPRIGHT (1) by using two M6 x 60mm SCREWS (51) and two 1/4" WASHERS (52) from the back of the FRONT UPRIGHT (1).
- ❑ Attach the THIGH HOLD DOWN (19) to the FRONT UPRIGHT (1) by using four M10 x 70mm SCREWS (41), eight 3/8" WASHERS (39), and four M10 HEX NYLOCK NUTS (53) through the FRONT SHROUD (15) and through the FRONT UPRIGHT (1). Tighten SECURELY.

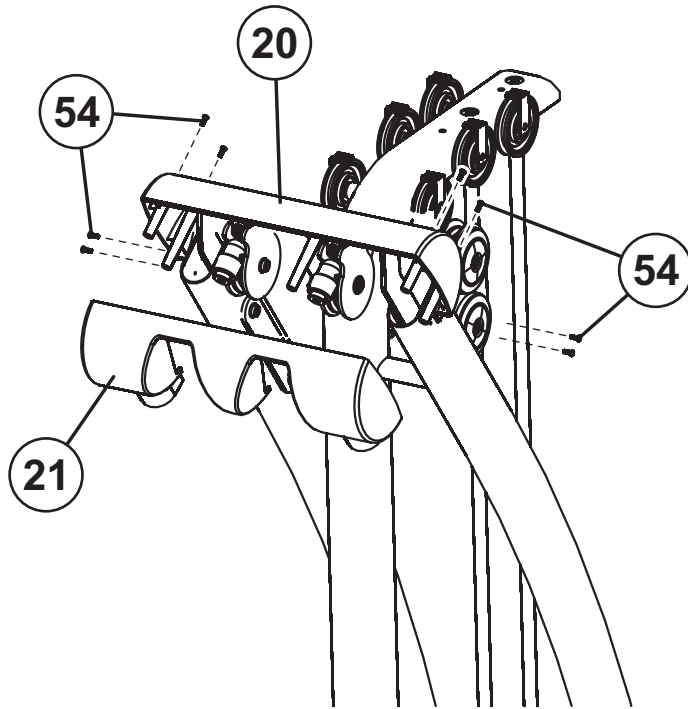

STEP 9:

- ❑ Attach the TOP FRONT COVER (21) to the TOP BACK COVER (20) using eight M4 ZINC PHILLIPS PAN HEAD SCREWS (54). DO NOT OVERTIGHTEN SCREWS INTO PLASTIC PARTS.

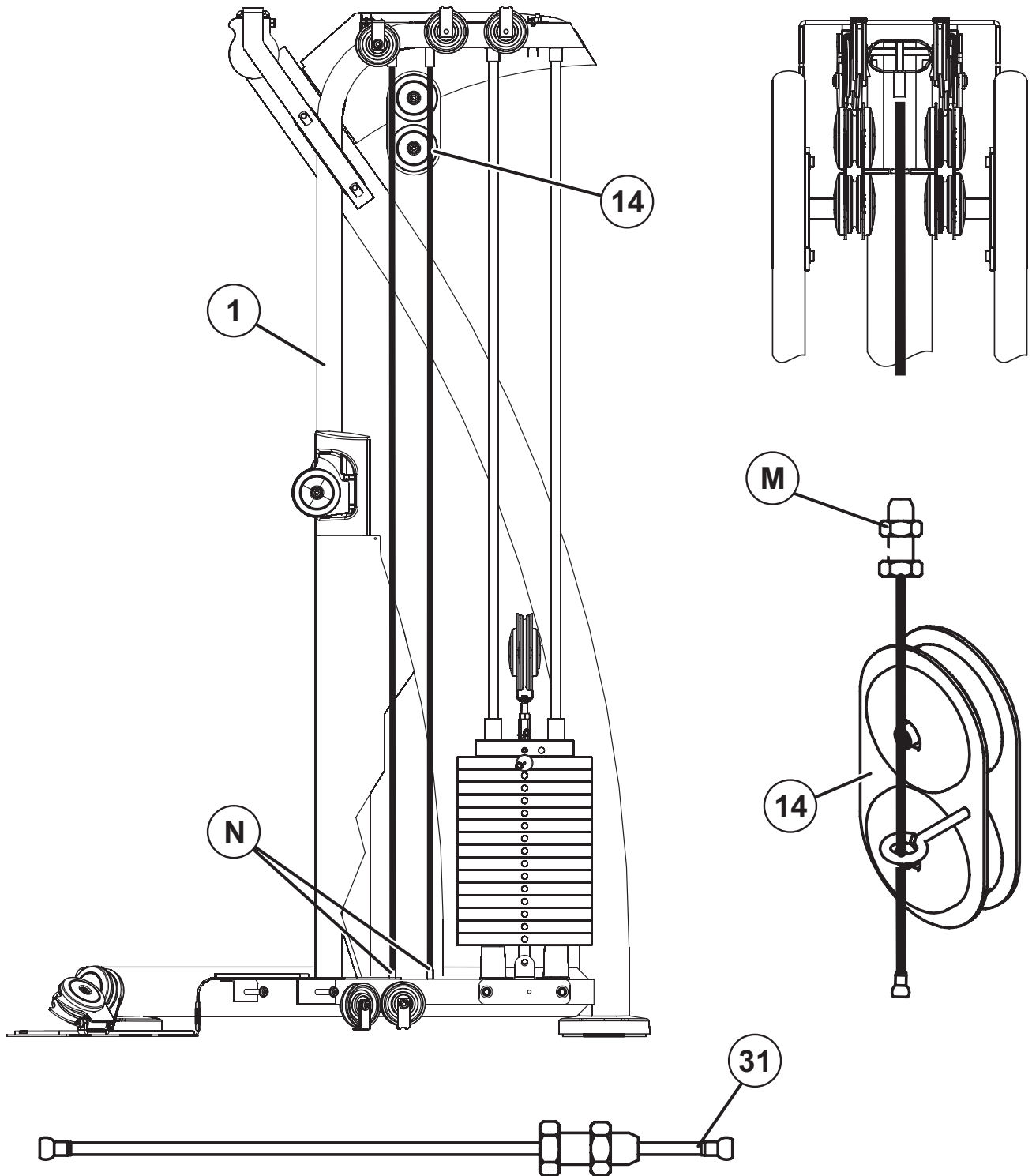

STEP 10:

- ❑ Insert the ball end of one GUIDE CABLE (31) through the eye hook on one FLOATING PULLEYS (14). Insert and hook the ball end of the cable into the SLOTTED BUSHING (N) located at the bottom of the frame located directly below the FLOATING PULLEYS (14).
- ❑ Screw the threaded end of the cable into the FRONT UPRIGHT (1) and loosely tighten the cable by screwing the JAM NUT (M) to the top of the frame.
- ❑ **REPEAT THE ABOVE PROCESS FOR THE REMAINING GUIDE CABLE (31).**

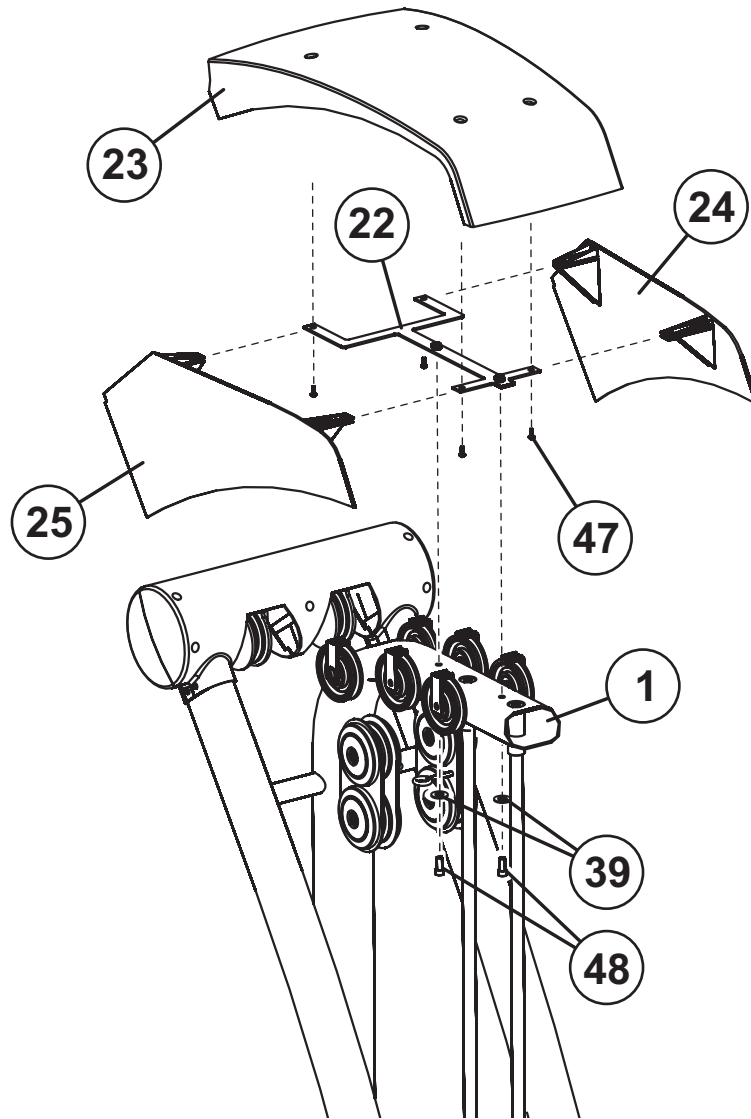

STEP 11:

- ❑ Assemble the MOUNTING SHEET (22) to the top of the FRONT UPRIGHT (1) using two M10 x 20mm SCREWS (48) and two 3/8" WASHERS (39). Tighten screws SECURELY.
- ❑ Attach the TOP LEFT COVER (25), the TOP RIGHT COVER (24) and the TOP COVER (23) to the MOUNTING SHEET (22) using four M4 x 0.7 ZINC PHILLIPS PAN HEAD SCREWS (47). DO NOT OVERTIGHTEN SCREWS INTO PLASTIC PARTS.

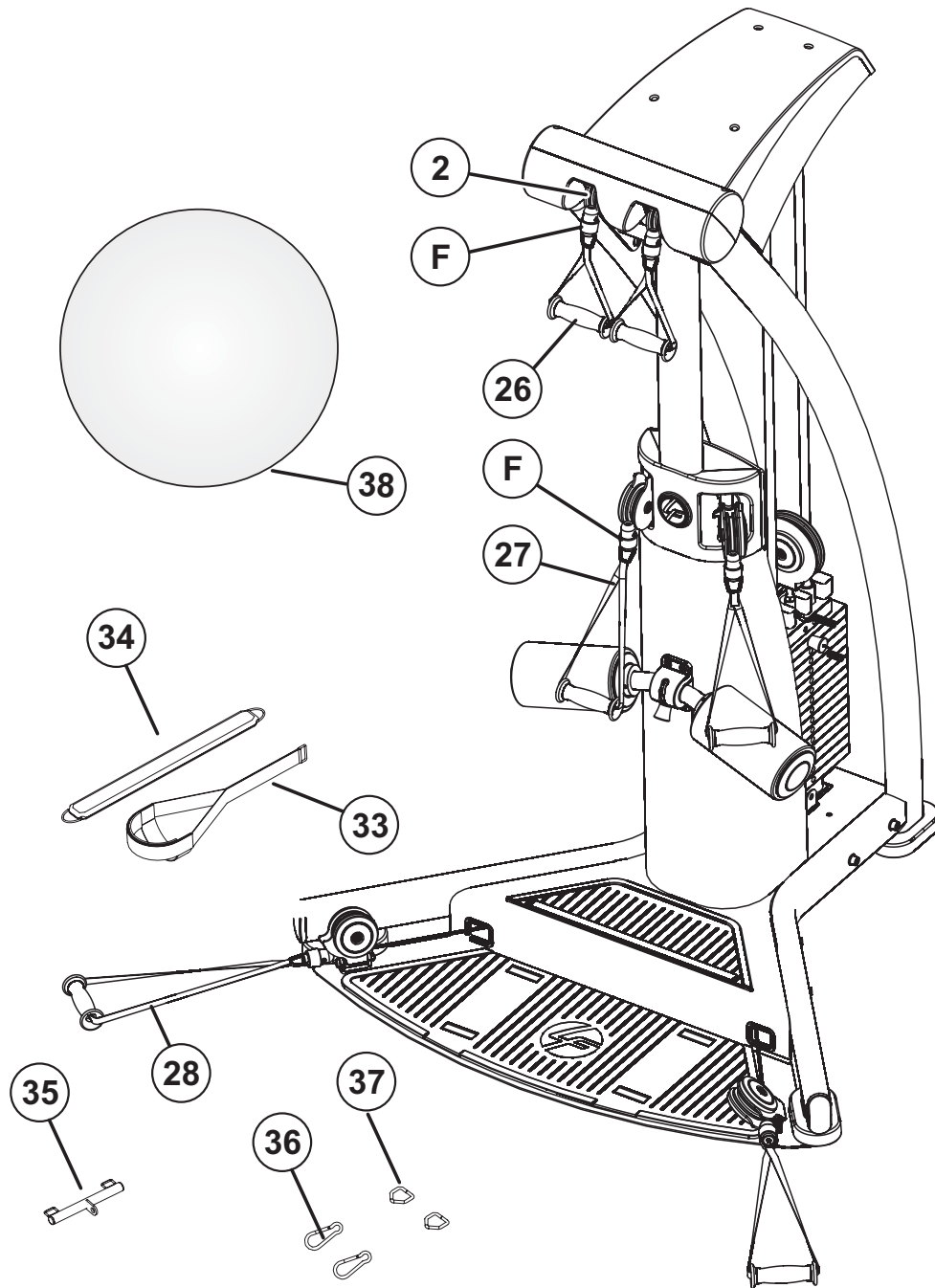

STEP 12:

- ❑ Referencing step 5, at the UPPER SWIVEL PULLEYS (2) push back on the QUICK CONNECT SLEEVE (F) at the end of each cable and attach the SHORT HANDLES (26).
- ❑ Repeat the process for attaching the ADJUSTABLE HANDLES (28) to the lower cable ends and the MEDIUM HANDLES (27) to the middle cable ends.

NOTE: THE HANDLE CONFIGURATION DEFINED WILL ACCOMMODATE MOST EXERCISES.

NOTE: THE FOOT STRAP (33) IS TO BE ATTACHED TO ONE OF THE MID SECTION PULLEY CABLE ENDS FOR LEG EXTENSIONS AND TO ONE OF THE LOWER PULLEY CABLE ENDS FOR LEG CURL EXERCISES.

MAINTENANCE

Please note:

- * We recommend cleaning your product (pads and frame) on a regular basis, using warm soapy water. Touch-up paint can be purchased from your Life Fitness customer service representative at (800) 351-3737.
- * Inspect equipment before each use. Tighten all loose connections and replace worn parts immediately. Failure to do so may result in serious injury.

*** PLEASE RECORD THE INFORMATION REQUESTED BELOW. IN THE EVENT YOU MAY NEED SERVICE YOU WILL BE ASKED FOR THIS INFORMATION. REMEMBER TO FILL OUT YOUR WARRANTY REGISTRATION CARD ON-LINE AT WWW.LIFEFITNESS.COM.**

Model #: _____

Serial #'s: _____

Note: The Model/Serial Number label is located towards the bottom of the RIGHT UPRIGHT.

Date of Purchase: _____

Dealer's Name _____

Dealer's Phone# _____

**Thank you for purchasing the Life Fitness
G5 CABLE MOTION GYM SYSTEM**

LIMITED WARRANTY

Life Fitness® G5 Cable Motion™ Gym System

Life Fitness extends the following LIMITED WARRANTY to the original owner (proof of purchase required, keep your receipt with this manual) of the Life Fitness product. The Warranty terms apply to IN HOME and LIGHT INSTITUTIONAL USE ONLY.

- LIMITED WARRANTY ON FRAME AND WELDS.** If the frame of the Life Fitness product or a weld should crack or break, it will be repaired or replaced by Life Fitness. Terms: IN HOME USE ONLY: Lifetime – for so long as the Customer owns the Life Fitness product; LIGHT INSTITUTIONAL USE: Ten (10) years.
- LIMITED WARRANTY ON PARTS.** If the following parts are defective in material or workmanship, Life Fitness will supply replacement parts: all bolts, nuts, washers, bearings, bushings, pulleys, thumbscrews, collars, cable retaining clips, adjustable pre-stretch slides, roller pad shafts, allen head bolts, weight selector pin, weight stack shaft, set screws, protector caps, adjustment chain, cotter pin, plunger, spring and knob. Terms: IN HOME USE ONLY: Lifetime – for so long as the Customer owns the Life Fitness product; LIGHT INSTITUTIONAL USE: One (1) year.
- LIMITED WARRANTY ON CABLES AND UPHOLSTERY.** If the coated cables or upholstery are defective in material or workmanship, Life Fitness will repair or replace them, at its option. Terms: IN HOME USE ONLY: Three (3) years; LIGHT INSTITUTIONAL USE: Ninety (90) days.
- CONDITIONS AND EXCEPTIONS.** Any product misuse, abuse or alteration, any attempt to repair by a person other than an authorized Life Fitness Service Center, any improper assembly, accident, or any other condition resulting from occurrences beyond the control of Life Fitness will void this Limited Warranty.
- REPLACEMENT AND REPAIR EXPENSES.** Life Fitness will provide only replacement parts or repair under this warranty. The Owner is responsible for all other costs. Such costs may include, but are not limited to: a. labor charges for service, removal, repair or reinstallation of the Life Fitness product or any component part; b. shipping, delivery, handling and administrative charges for returning parts to Life Fitness; and c. all necessary or incidental costs related to installation of the replacement parts.
- SHIPPING.** If shipping by the Owners is deemed necessary (in sole discretion of Life Fitness), parts should be shipped in their original carton or equivalent packaging, fully insured with shipping charges prepaid. Life Fitness will not assume any responsibility for any loss or damage incurred in shipping.
- CLAIM PROCEDURES.** If service on your Life Fitness product is required during the warranty period, please contact our Customer Service Department at 1-800-351-3737 (U.S. and Canada) or +1-847-288-3300 (outside of U.S. and Canada) for instructions regarding returning or replacing parts. Please have available the following information: (i) the dealer's name; (ii) the date of purchase; (iii) the serial # (s) of your product(s) (the serial number location is called out on the final assembly drawing included with your assembly instruction); (iv) a description of the nature of the problem.
- OWNER'S RIGHT.** This Limited Warranty gives you specific legal rights. You may also have other rights, which vary depending on local law.
- LIMITATION OF IMPLIED WARRANTIES.** All implied warranties, except to the extent prohibited by applicable law, shall have no greater duration than the warranty period set forth above. There are no warranties which extend beyond the description in this Limited Warranty. Because local laws do not allow limitations on how long an implied warranty lasts, the above limitations may not apply to you.
- DISCLAIMER.** No other express warranty has been made or will be made on behalf of Life Fitness with respect to any Life Fitness product or the operation, repair or replacement of any Life Fitness product. Life Fitness shall not be responsible for injury, loss of use of the Life Fitness product, inconvenience, loss or damage to personal property, whether direct or indirect, and incidental or consequential damages, so the above limitation or exclusion may not apply to you.

Notes:

CORPORATE HEADQUARTERS
5100 North River Road
Schiller Park, Illinois 60176 • U.S.A.
847.288.3300 • FAX: 847.288.3703
800.735.3867 (Toll-free within U.S.A., Canada)

INTERNATIONAL OFFICES

AMERICA'S

North America
Life Fitness Inc.
5100 N River Road
Schiller Park, IL 60176 U.S.A
Telephone: (847) 288 3300
Fax: (847) 288 3703

Brazil
Life Fitness Do Brazil

Av. Dr. Dib Sauaia Neto 1478
Alphaville, Barueri, SP
06465-140
BRAZIL
Telephone: (800) 773 8282
Fax: (+55) 11.4133.2893

Latin America & Caribbean*
Life Fitness Inc.

5100 N River Road
Schiller Park, IL 60176 U.S.A
Telephone: (847) 288 3300
Fax: (847) 288 3703

EUROPE, MIDDLE EAST, & AFRICA
(EMEA)

Netherlands & Luxemburg
Life Fitness Atlantic BV

Bijdorpplein 25-31
2992 LB Barendrecht
THE NETHERLANDS
Telephone: (+31) 180 646 666
Fax: (+31) 180 646 699

United Kingdom & Ireland
Life Fitness UK LTD

Queen Adelaide
Ely, Cambs, CB7 4UB
Telephone: General Office (+44) 1353.666017 Customer
Support (+44) 1353.665507
Fax: (+44) 1353.666018

Germany & Switzerland
Life Fitness Europe GMBH

Siemensstrasse 3
85716 Unterschleissheim
GERMANY
Telephone: (+49) 89.31 77 51.0 (Germany)
(+41) 0848 000 901 (Switzerland)
Fax: (+49) 89.31 77 51.99 (Germany)
(+41) 043 818 07 20 (Switzerland)

Austria
Life Fitness Austria
Vertriebs G.m.b.H.
Dückerstrasse 7-9/3/36
1220 Vienna
AUSTRIA
Telephone: (+43) 1.61.57.198
Fax: (+43) 1.61.57.198.20

Spain
Life Fitness IBERIA
C/Frederic Mompou 5,1^o1^a
08960 Sant Just Desvern Barcelona
SPAIN
Telephone: (+34) 936 724 660
Fax: (+34) 936 724 670

Italy
Life Fitness ITALIA S.R.L.

Via Crivellini 7/N
37010 Affi Verona
ITALY
Telephone: (+39) 045.7237811
Fax: (+39) 045.7238197

Belgium
Life Fitness Benelux NV
Parc Industriel de Petit-Rechain
4800 Verviers
BELGIUM
Telephone: (+32) 87 300 942
Fax: (+32) 87 300 943

All Other EMEA countries & distributor business C-EMEA*
Bijdorpplein 25-31
2992 LB Barendrecht
THE NETHERLANDS
Telephone: (+31) 180 646 666
Fax: (+31) 180 646 699

ASIA PACIFIC (AP)

Japan
Life Fitness Japan
Nippon Brunswick Bldg., #8F
5-27-7 Sendagaya
Shibuya-Ku, Tokyo
Japan 151-0051
Telephone: (+81) 3.3359.4309
Fax: (+81) 3.3359.4307

China and Hong Kong
Life Fitness Asia Pacific LTD
Room 2610, Miramar Tower
132 Nathan Road
Tsimshatsui, Kowloon
HONG KONG
Telephone: (+852) 2891.6677
Fax: (+852) 2575.6001

All Other Asia Pacific countries & distributor business Asia Pacific*

Room 2610, Miramar Tower
132 Nathan Road
Tsimshatsui, Kowloon
HONG KONG
Telephone: (+852) 2891.6677
Fax: (+852) 2575.6001

* Also check www.lifefitness.com for local representation or distributor/dealer.